

TURBOFARMER II

TF35.7-100

- ▶ **Kubota Tier III Engine**, 100Horsepower
- ▶ **Boom Suspension System (BSS)** delivers active dampening during material handling
- ▶ **Improved acceleration** and higher maximum speed ensures greater productivity
- ▶ **Lower hydraulic pressure** ensures **reduced wear** and prevents oil over-heating

SINCE 1964



The mid-range TF35.7-100 Merlo telehandler is small on space and big on power.



TURBOFARMER II

TF35.7-100

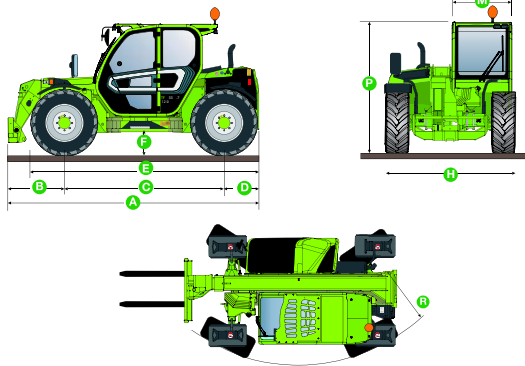

DIMENSIONS

A (mm)	4,310
B (mm)	970
C (mm)	2,740
D (mm)	600
E (mm)	3,910
F (mm)	380
H (mm)	2,250
M (mm)	995
P (mm)	2,240
R (mm)	4,095

PERFORMANCE

Unladen Weight (kg)	6,650
Maximum Load Capacity (kg)	3,500
Maximum Lift Height (m)	6.6
Capacity at Maximum Height (kg)	3,000
Maximum Reach (m)	3.5
Capacity at Maximum Reach (kg)	1,250

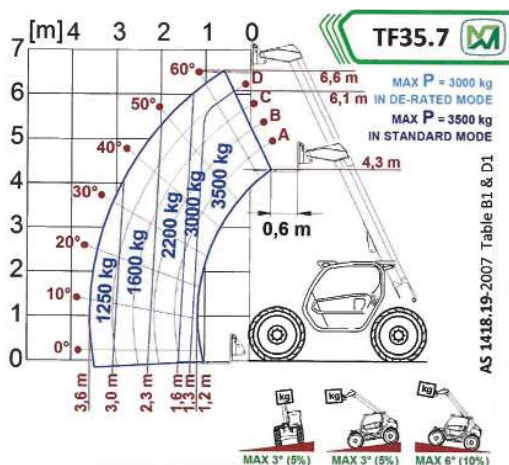

STANDARD SPECIFICATIONS

Engine	
Turbo Engine	Kubota V3800 Euro III
Range/Cylinders	3800/4
Engine Power (kW/HP)	74/100
Maximum Speed (km/h)	40
Fuel Tank Capacity (l)	80

Transmission	
Hydrostatic Merlo Transmission	Std
Speeds	2
Dual Reverse Shuttle System	Std
Pedal Inching-Control	Std
Permanent Four-Wheel Drive	Std

Brakes	
Automatic Parking Brake	Std
External Dry Disc Service Brakes	Std

Tyres	
Standard Tyres	405/70-24

Cab	
Air Conditioned Cabin	Std
Pressurized Cabin	Std
Air Suspension Seat	Std
FOPS (ISO 3449) and ROPS (ISO 3471) Cab	Std

Steering	
All Wheel Steering	Std

Instruments	
Electronic Joystick Control	Std
Merlo Dynamic Load Control (M-CDC)	Std
Reversing Camera	Std

Hydraulic System-Implement	
LS Flow-Sharing Hydraulic System (bar-l/min)	210-125
BSS Hydro-Pneumatic Boom Suspension	Std
Hydraulic Oil Tank Capacity (l)	85
Fan Drive Pump (l/min)	46
Auxiliary Hydraulic Service on Boom	Std

Accessories and Attachments	
Tac-Lock Attachment Locking	Std
Standard Forks	Std
Fork Extensions	Optional
Digging Bucket	Optional
Re-Handling Bucket	Optional
4 x 1 Bucket	Optional
Multipurpose Bucket with Grab	Optional
Crane Hook	Optional
Reduced Height Crane Jib	Optional
Drum Clamp	Optional
Forks with Slide Protection	Optional
Handler for Single Round Bale	Optional
Fork Rotator	Optional
Carriage with Floating Forks	Optional

EXTRA SPECIFICATIONS

Hydraulic Reversible Fan	Std
--------------------------	-----



120-124 Toongabbie Road Girraween 2145 NSW Australia
For further information please call 1300 657 325 or visit merloaustralia.com.au

Merlo reserves the right to modify and update the contents of this document at any time. Information and technical data are as available at time of printing.

For current information on Merlo products please contact your Merlo dealer.

ABN 87116110751 MER-TF35.7-100-2018